

**VOLAT**

**VOLAT**

MINSK WHEEL TRACTOR PLANT



HEAVY EQUIPMENT TRANSPORTER  
MZKT-741501+720100

VEHICLES OVERCOMING ALL OBSTACLES

# HEAVY EQUIPMENT TRANSPORTER

## MZKT-74 1501+720100

### SPECIFICATIONS

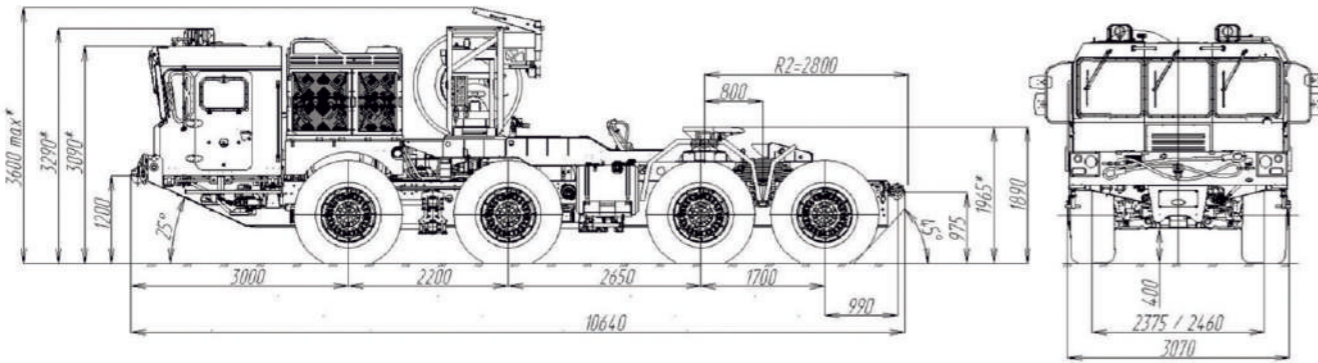

TRACTOR HEAD MZKT-74 1501

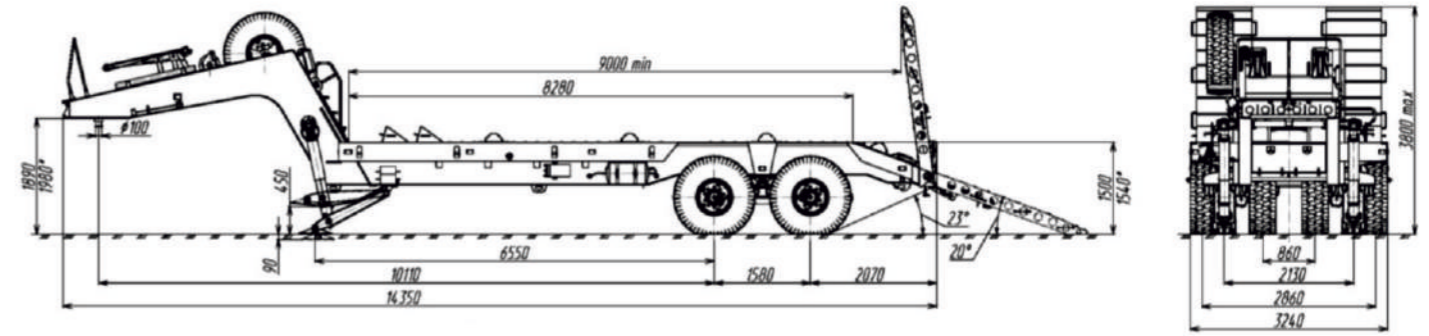

SEMITRAILER MZKT-720100

#### PERFORMANCE DATA

Wheel drive	8x8
Max. speed, km/h	70
Gradeability, %	20
Turning radius, m	16
Fuel tank capacity, l	2x385
Cruising range, km	550
Operating temperature, °C	-45 ... +50
Air transportable	An-124, An-22, A400M, C-5

#### WEIGHT DATA

Curb vehicle weight, kg	24 800
Gross vehicle weight, kg	48 000
Permissible weight on axles, kg	
1-2 axles	23 000
3-4 axles	25 000
Fifth wheel load, kg	23 000
Gross combination weight, kg	95 000

#### ENGINE

Number and location of cylinders	V8
Power	368 kW (500 h.p.) at 2 100 min <sup>-1</sup>
Max. torque	1 960 Nm at 1 300 min <sup>-1</sup>

#### TRANSMISSION

Type	automatic
Model	MZKT-5561
Number of gears	6 forward, 1 reverse
Gear ratio	4.40-0.65; R 4.95

#### TRANSFER CASE

2-speed, lockable inter-bogie differential

#### DRIVING AXLES

Split, with central reduction gears, interaxle and cross-axle differential lock

#### AXLE SUSPENSION

1st and 2nd axles - independent torsion-bar  
3rd and 4th axles - dependent spring-balanced

#### STEERING SYSTEM

Left-hand drive  
Hydraulic power assisted

#### BRAKE SYSTEM

Drum brakes of shoe-type with air-hydraulic drive  
Engine brake  
Electrodynamical retarder

#### TYRES

1500x600-635, offroad protector  
Central tyre inflation system (CTIS)

#### FRAME

Longitudinal  
Equipped with front and rear towing units

#### CAB

2-door fiberglass, 3-seat  
Equipped with ventilation and heating systems  
Air-conditioner  
Filter-ventilation unit

#### ELECTRICAL EQUIPMENT

Nominal voltage 24 V  
Single-wire  
Batteries 4x190 Ah

#### FIFTH WHEEL

MZKT, king pin diameter 100 mm

#### WINCH

Twin winch with hydraulic drive  
Max. towing force 2x200 kN  
Rope length 60 m

For transportation of various heavy tracked and wheeled vehicles or heavy loads with max weight of 52 000 kg

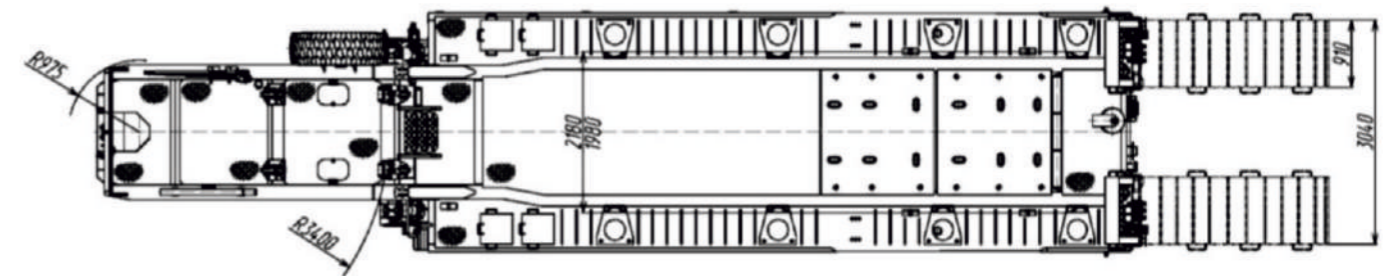

#### WEIGHT DATA

Curb semitrailer weight, kg	16 000
Payload, kg	52 000
Gross semitrailer weight, kg	68 000
Permissible weight on axles, kg	2x22 500
Load on fifth wheel, kg	23 000

#### AXLES

Two independent 4-wheel bogies, wheels of each bogie are connected in pairs by wheel equalizer beams  
Equalizing type suspension

#### TYRES

16.00R20, offroad protector  
Number of wheels - 8+1

#### CARGO PLATFORM

Frame sheet flooring with anti-skid plates

#### BRAKE SYSTEM

Drum brakes of shoe-type with pneumatic drive from tractor brake valve

#### ELECTRICAL EQUIPMENT

Nominal voltage 24 V  
Single-wire

#### RAMPS

Tilted one-section loading ramps with mechanic drive

#### SPECIAL EQUIPMENT

Spare wheel lifting mechanism with manual drive  
Support and guide rollers  
Winch rope guide blocks  
Linen straps for cargo fixation  
Bumper bars